

MTWD (Digital Wrench) Operating Instructions

Rev 1.0 (3/29/2012)

MTWD Digital Torque Wrenches

The MTWD is digital wrench that provides a digital display of torque readings. The tool is designed for daily screw tightening production environment and provides a visual, acoustic and sensory signal (handle vibrates) when the pre-set torque is reached.

Features

- Accuracy +/- 2.5% of reading CW, +/- 1 digit
Accuracy +/- 3% of reading CCW, +/- 1 digit
- Designed for daily screw tightening production environment.
- Program pre-set torque.
- Visual, acoustic and sensory signal (handle vibrates) when the set torque is reached.
- Four units of torque measurement available: N.m, lbf.ft, lbf.in, kgf.m
- Heavy duty bi-directional ratchet head
- Operating mode: Peak
- Holds "Peak" torque readings for 15 seconds.
- Large LCD screen for high visibility.
- Soft texture ergonomic grip.
- Four-digit display
- Battery operation



Install Batteries

1. Unscrew the screw with phillips screwdriver. Remove end cap. Remove the two battery holders.

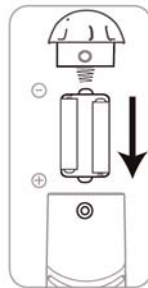

2. Install (6) high quality AAA batteries with the two battery holders. Install the batteries in the correct direction.

Notes: Remove batteries if you don't plan to use the wrench for an extended period of time. Replace batteries as soon as possible when dead.



3. Insert end cap back on. Tighten the screw with phillips screwdriver.

Notes: Only use AAA batteries. Improper battery may damage torque wrench.

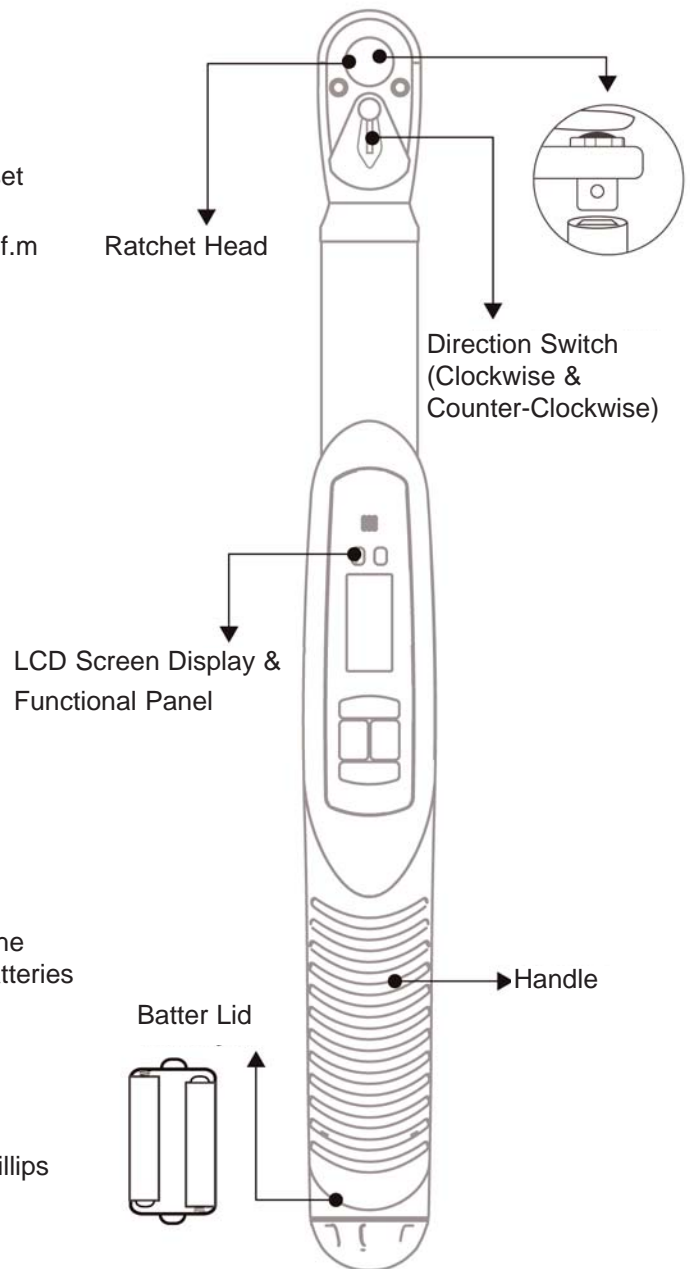

MTWD (Digital Wrench) Operating Instructions

Rev 1.0 (3/29/2012)

Low Battery

When battery capacity reaches a level with only 30% power left, the battery icon on the display will flash. The digital torque wrench is still workable but you should replace the battery soon.

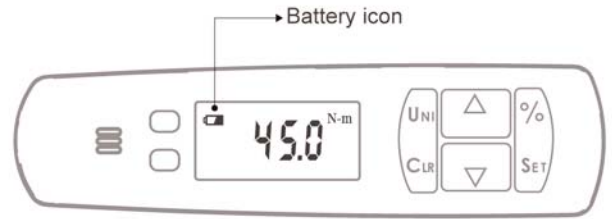

When battery capacity reaches a level with only 10% power left, the display will show the battery icon ONLY. The digital torque wrench will no longer operate. Replace the battery immediately.

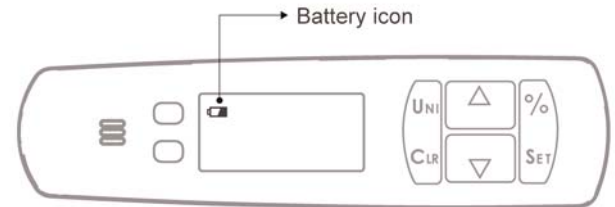

Digital Display & Functional Panel

Power On

To power on the wrench: Press any key for 3 seconds.

Note! It may damage the wrench if you turn it on while applying torque.

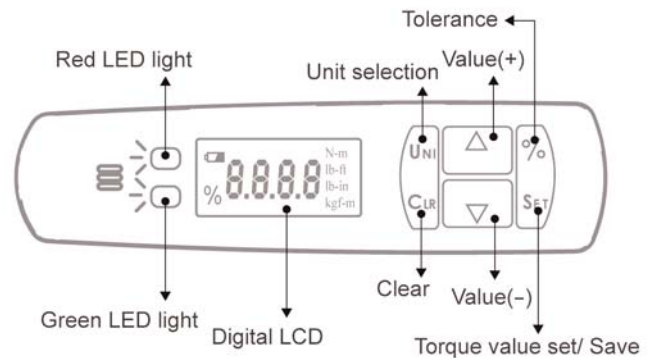

Power Off

1. Automatic: Without applying torque, the wrench automatically shuts off after 90 seconds when the display indicates "0".

2. Manual: Without applying torque, press CLR button for 5 seconds.

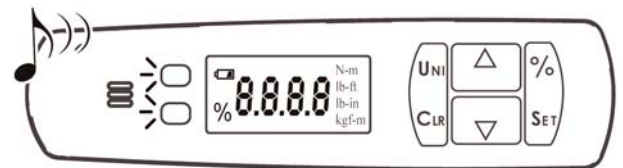

Switch Units

1. Press UNI button to select the torque measurement unit.

2. There are 4 torque units to select: N.m, lbf.ft, lbf.in, kgf.m



MTWD (Digital Wrench) Operating Instructions

Rev 1.0 (3/29/2012)

View/Change the Pre-set Torque Value:

Set the target or maximum torque value.

1. Without applying torque, press SET button to enter the pre-set torque value mode.



2. Press the upward arrow button to increase the torque value.
Press the downward arrow button to decrease the torque value.

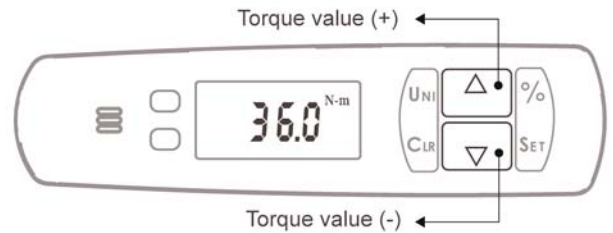

3. When the pre-set torque value is reached, press SET button to save the pre-set torque value.



4. Press CLR button to leave without saving.
Auto-Exit: If Idle for 6 seconds, it will leave set-up process without saving the pre-set torque value.

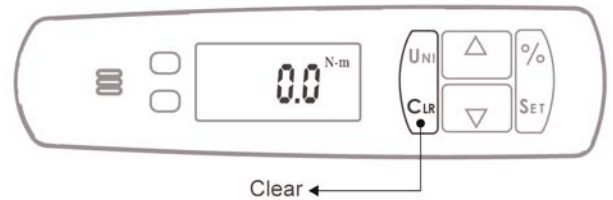

MTWD (Digital Wrench) Operating Instructions

Rev 1.0 (3/29/2012)

Set Tolerance Setting

The tolerance parameters control the Go and No-Go signal response. The user sets a lower and upper torque thresholds to get a visual and audible warning signals when these limits are reached or breached during operation. This function is primarily used for safety and quality control.

The digital wrench features a tolerance range: 5% ~ 50%

1. Without applying torque, press % button to enter the tolerance setting mode.
2. Press the upward arrow button to increase the tolerance value. Press the downward arrow button to decrease the tolerance value.
3. When the desired tolerance value is reached, press % button to save the tolerance value.
4. Press CLR button to leave without saving.
Auto-Exit: If Idle for 6 seconds, it will leave set-up process without saving the tolerance value.

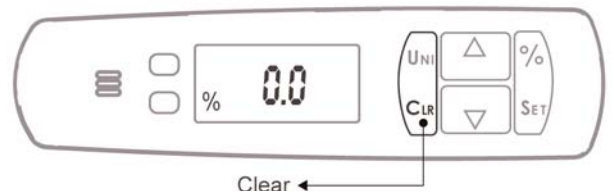
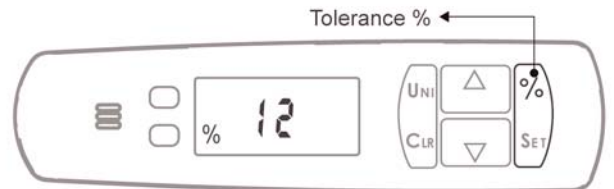
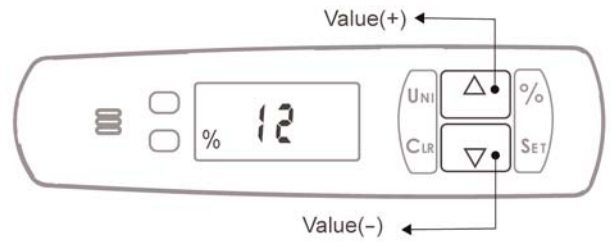

Vibration

When applied torque reaches the pre-set torque value, the handle starts vibrating. The vibration will stop once the operator stops applying torque.

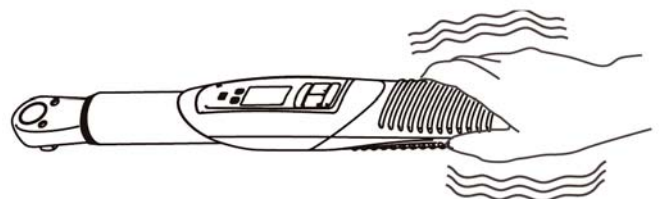

MTWD (Digital Wrench) Operating Instructions

Rev 1.0 (3/29/2012)

Light & Buzzer (Beep Tone) Alert

The tolerance setting provides a visual and sound signal if the torque Passed or Failed. When applied torque reaches the pre-set torque value, the GREEN & RED lights are on and the buzzer beeps continuously. The LCD display shows the maximum applied torque for 15 seconds then indicates "0".

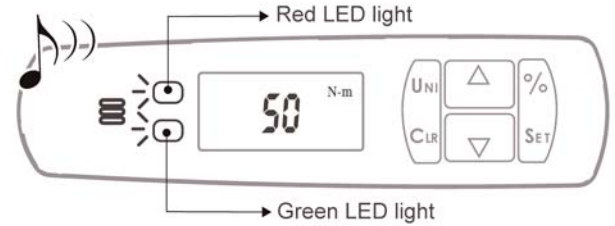

When applied torque exceeds the wrench full-scale capacity, the GREEN & RED lights are on and the buzzer beeps continuously. Display shows "----"

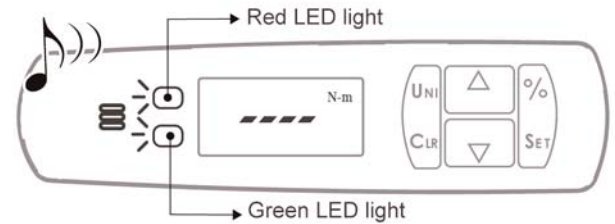

Example

Condition: Torque value is set to 45 N.m, and the tolerance is set to -10%

An alert tone will occur at 40.5 N.m. There will be a rapid pulsing tone to indicate the torque value is closing to the target value (45 N.m).

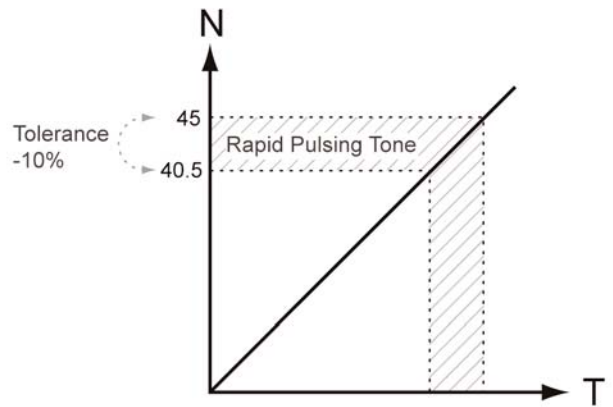

MTWD (Digital Wrench) Operating Instructions

Rev 1.0 (3/29/2012)

Applying Torque

1. Make sure the digital torque wrench is not applying torque and then press any key for 3 seconds to turn on the tool.

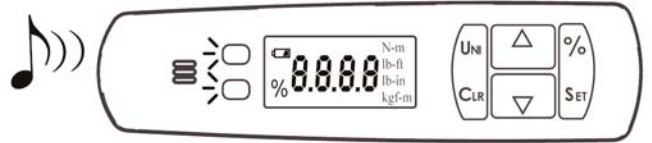

2. Use correct size of the socket to for the application.

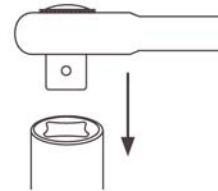

3. Tighten nut or bolt by applying a steady even pull using built in ratchet as necessary. Wrench should be kept at 90 degrees to axis of bolt during tightening. When pre-set torque is reached, the wrench will provide a visual, acoustic and sensory signal (handle vibrates) when the set torque is reached.

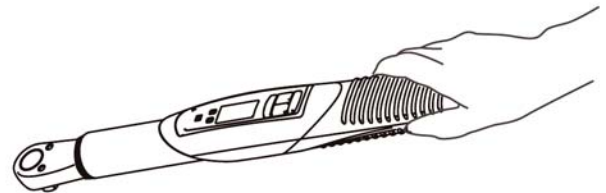
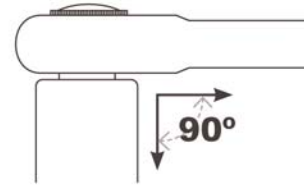

4. Press CLR button every time before operating the tool again.

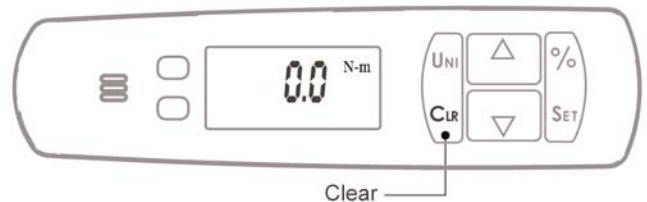



MTWD (Digital Wrench) Operating Instructions

Rev 1.0 (3/29/2012)

Calibrating Torque Wrenches

To calibrate torque wrenches either use a torque tester or torque sensor within the range of the torque wrench. Make sure to apply the torque slowly and smoothly.

Note: Refer to ISO6789 International Standard for more information on hand tool testing requirements.

Mountz Calibration & Repair Services

Mountz Inc. features an experienced calibration and repair staff. Our trained technicians can calibrate and repair most any tool. Mountz provides rapid service with quality that you can trust as we offer three state-of-the-art calibration lab and repair facilities that can calibrate up to 20,000 lbf.ft.

With over 50 years of experience, Mountz's in-depth knowledge of torque is reflected in our tool's craftsmanship and our ability to provide solutions to both common and uncommon torque applications. We perform calibrations in accordance with ANSI/NCSL-Z540. Mountz is dedicated solely to the manufacturing, marketing and servicing of high quality torque tools.

Mountz is an ISO 9001 certified and ISO 17025 accredited company.

Tool Service & Repair Capability

- Torque Wrench Calibration: Click Wrench, Dial Torque Wrench, Beam Wrench, Cam-Over & Break-Over Wrench
- Torque Screwdrivers: Dial, Micrometer, Preset & Adjustable
- Torque Analyzers/Sensors: All brands
- Electric Screwdrivers: All brands
- Air Tools: All brands
Impact Wrenches, Drills, Pulse Tools, Grinders, Percussive Tools, Air Screwdrivers, Nutrunners, DC Controlled Nutrunners
- Torque Multipliers: All brands

Mountz Torque Testers and Calibration Equipment

Torque tools go out of calibration with use. Calibrating a torque tool is a fine-tuning process of bringing the tool back within its tolerance. Torque testers can also be used for quick tools tests on the line or in the lab to determine whether torque tools are holding a given setting.

A regular torque tool calibration and re-calibration guarantees the operator repeatable accuracy and adherence to international standards. Torque testing also ensures torque equipment is operating to peak performance and can highlight potential tooling problems before they arise perhaps due to tool wear or broken components.

Controlling torque is essential for companies to ensure their product's quality, safety and reliability isn't compromised. The failure of a three-cent fastener that isn't properly tightened can lead to catastrophic or latent failures. Fasteners that are insufficiently torqued can vibrate loose and excessive torque can strip threaded fasteners. Using a quality torque tool has become increasingly important for many companies to ensure that proper torque is being applied and maintains gauge requirements associated with the ISO 9001 Quality Standard. Look for the Mountz hexagon logo - it's a stamp for quality tools, service and knowledge in the field of torque control.

Mountz Service Locations

Eastern Service Center

19051 Underwood Rd.
Foley, AL 36535
Phone: (251) 943-4125
Fax: (251) 943-4979

Western Service Center

1080 N.11th Street
San Jose, CA 95112
Phone: (408) 292-2214
Fax: (408) 292-2733

www.mountztorque.com
sales@mountztorque.com



Twitter: @mountztorque

Download a "Service Form" and include a copy when you send the tools in to be serviced.

Looking for fasteners?
www.mrmetric.com

**mr.
metric**
your trusted source for screws, nuts, washers and
a division of Mountz, Inc. - established 1965