

SU1200/850/650

摩擦式鋸片研磨機 Friction Saw Blade Sharpening Machine

Professional class friction saw blade sharpening machine

專業級的摩擦式鋸片研磨機

Superior innovation and brand new design 全新設計

- A new generation design based on years practical experience and therefore create one professional class friction saw blade sharpening machine. 本機經過多年的精心設計，是一部專業級的摩擦式鋸片研磨機。
- The patented vertical grinding direction allows you to operate it easy. 專利直立式鋸片研磨方式，可以使您輕易的操作機器。
- Brand new design: The vertical type friction saw blade sharpening machine is made with the thinking of operator as top priority. All adjustment levers have been properly arranged, which allows operator to adjust rather easily cutting angle, back clearance angle, teeth depth and pitch of saw blade. Therefore, grinding sharp saw blade became quick and precise.

全新的設計，本著操作者的立場所設計的直立式摩擦式鋸片研磨機，其所有的調整桿，均做了合理的排列，讓操作者可以很容易調整鋸齒的切削角、背隙角、齒深及齒距，所以可以快而準確的研磨出鋒利的鋸片。

Patented saw blade thickness adjustment 專利的鋸片厚度調整

- Saw blade thickness is clamped by two synchronic movement mechanisms at the same time. It can help the saw blade in the center position. Therefore, no need to adjust manually the thickness of saw blade. Besides, as saw blade is clamped well, the grinding noise can be lowered. 鋸片厚度經兩個同動的機構同時夾持，可將鋸片夾持在中心位置，所以不必再手動調整鋸片厚度。同時因為將鋸片夾持研磨，所以可以降低研磨時的噪音。

Manual speed variation 無段變速

- The machine equipped with inverter which can control the speed of grinding. 使用變頻器來控制研磨速度。
- The grinding speed can be adjusted with the change of teeth pitch. 可隨齒距的變化來調整所需要的研磨速度。

Tooth profile cam 齒形凸輪

- Industrial class specialized tooth-profile cam was designed by high accurate calculation & simulation computer system. This makes your saw blade grinding done even more simply, quickly, and accurately. 經過電腦精密計算模擬，所設計出的工業級專業齒形凸輪，使你的鋸片研磨更為簡單、快速精準。

- Carbide tungsten is welded onto the end part of pushing jaw, which can reduce the wearing of feeding jaw to minimal possible extent and can reach accurate feeding. 推進爪末端焊有碳化鎢，可使進給爪的磨損減至最低，以達到精確的推給。
- All cast iron of this machine utilizes nodular cast iron (FCD-45). And they have been tempered to ensure the accuracy and enhance wear resistance. 本機所有的鑄鐵均採用球狀石墨鑄鐵(FCD-45)，並經回火處理，以確保精度，及增加耐磨性。
- Main parts all utilize SKD 11 high carbide steel and have been through grinding and heat treatment. 主要零件均採用SKD11高碳鋼，並經熱處理研磨。
- The spring for push arm is what has been reformed. With rotary spring, it won't get elastic fatigue easily (elasticity won't give in so easily). This can ensure the accuracy of feeding. 推臂彈簧經過改良，使用回轉式彈簧，不易彈性疲乏，確保推給準確。
- Prop stand for feeding shaft of saw blade: Use high strength copper alloy as basic material with high-tech made solid lubricant added inside. It got features of high loading capacity and wearing resistance even without any need to apply lubricant additionally. 鋸片推給軸支持座，使用高強度銅合金作基材，埋入高科技技術製造之固體潤滑劑，其高負荷、耐磨耗的特性更達到完全無給油功能。
- Feeding shaft use $\varnothing 30\text{mm}$; enlarge axle center and heat treatment and grinding. 推給軸使用 $\varnothing 30\text{mm}$ ，加大軸心並經熱處理及研磨。

SU1200

摩擦式鋸片研磨機 Friction Saw Blade Sharpening Machine



Grinding Series 研磨例

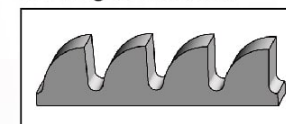

Friction Saw Blade 摩擦式鋸片

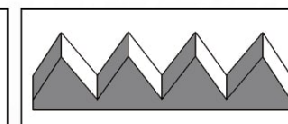

Friction Saw Blade ECO



Stepless speed variation adjustment button 無段變速調整鈕

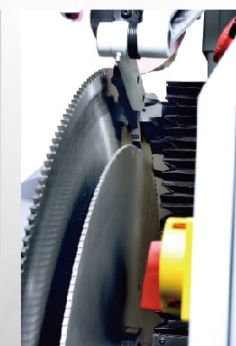

Measurement 尺寸圖

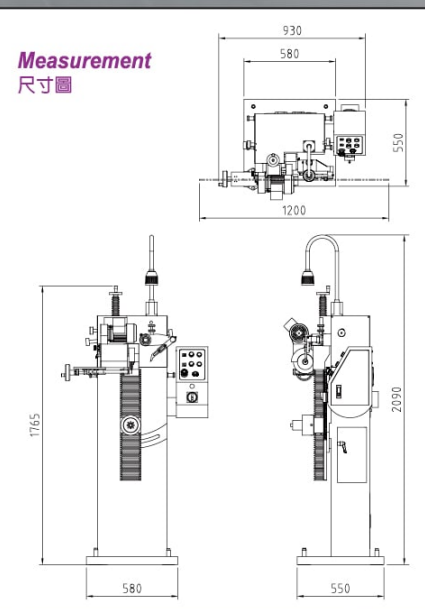

Specifications 規格表

Grinding Range 研磨範圍	$\varnothing 450 \sim \varnothing 1200 \text{ mm}$
Teeth Pitch 齒距	25 mm
Saw Blade Thickness 鋸片厚度	12 mm
Grinding Speed 研磨速度	10~100
Cutting Angle 切削角	-5~+15
Grinding Wheel Diameter 砂輪外徑	$\varnothing 180 \text{ mm}$
Grinding Wheel Motor 砂輪馬達	0.75 KW
Transmission Motor 傳動馬達	0.37 KW
Grinding Wheel Speed (50Hz / 60Hz) 砂輪轉速	3800/4500 rpm
Net Weight / Gross Weight 淨重/毛重	285 / 395 KG
Package Size 裝箱尺寸	85x120x215 cm
Standard Accessory 標準配備	
Work Light 工作燈	1 pc 個
Tool Box 工具箱	1 set 套
Instruction Manual 說明書	1 copy 份
Guide Plate 導板	1 pc 片
Grinding Wheel 砂輪	10 pcs 片

※ All designs, spec. and characteristics shown as above is subject to any change without further notice. 因設計或製造上的需要，如有變更恕不另行通知。

SU850 摩擦式鋸片研磨機

Friction Saw Blade Sharpening Machine



Grinding Series 研磨例

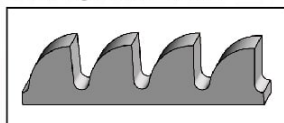

Friction Saw Blade 摩擦式鋸片

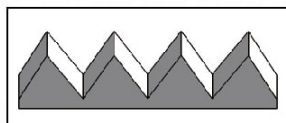

Friction Saw Blade ECO



Stepless speed variation adjustment button 無段變速調整鈕

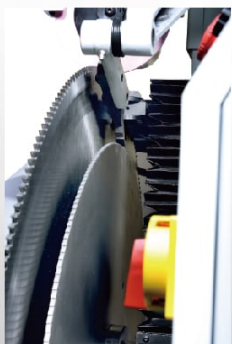

Measurement 尺寸圖

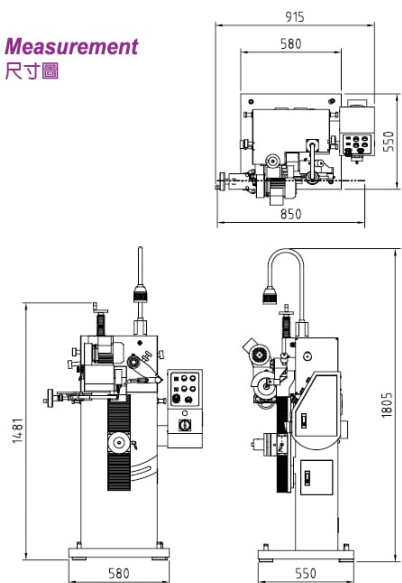

Specifications 規格表

Grinding Range 研磨範圍	Ø350~Ø850 mm
Teeth Pitch 齒距	25 mm
Saw Blade Thickness 鋸片厚度	12 mm
Grinding Speed 研磨速度	10~100
Cutting Angle 切削角	-5~+15
Grinding Wheel Diameter 砂輪外徑	Ø180 mm
Grinding Wheel Motor 砂輪馬達	0.75 KW
Transmission Motor 傳動馬達	0.37 KW
Grinding Wheel Speed (50Hz / 60Hz) 砂輪轉速	3800/4500 rpm
Net Weight / Gross Weight 淨重/毛重	259 / 385 KG
Package Size 裝箱尺寸	85x113x176 cm

Standard Accessory 標準配備

Work Light 工作燈	1 pc 個
Tool Box 工具箱	1 set 套
Instruction Manual 說明書	1 copy 份
Guide Plate 導板	1 pc 片
Grinding Wheel 砂輪	10 pcs 片

※ All designs, spec. and characteristics shown as above is subject to any change without further notice.
因設計或製造上的需要，如有變更恕不另行通知。

SU650 摩擦式鋸片研磨機

Friction Saw Blade Sharpening Machine



Grinding Series 研磨例

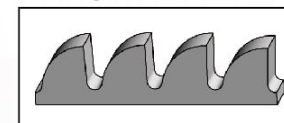

Friction Saw Blade 摩擦式鋸片

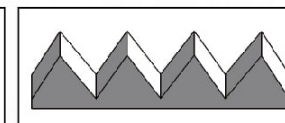

Friction Saw Blade ECO



Stepless speed variation adjustment button 無段變速調整鈕

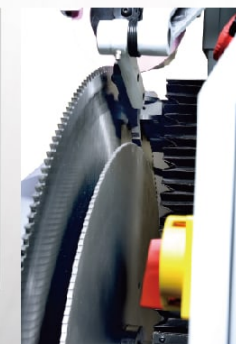

Measurement 尺寸圖

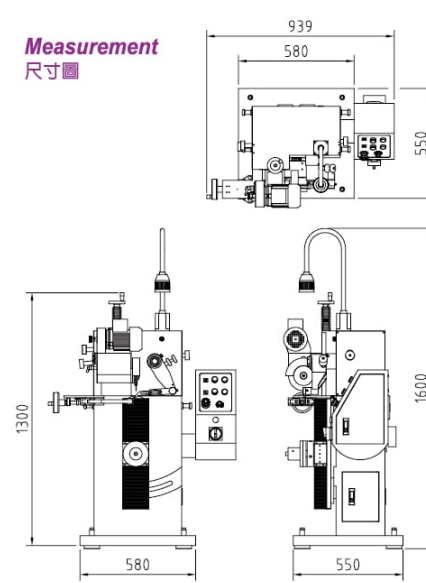

Specifications 規格表

Grinding Range 研磨範圍	Ø250~Ø650 mm
Teeth Pitch 齒距	25 mm
Saw Blade Thickness 鋸片厚度	12 mm
Grinding Speed 研磨速度	10~100
Cutting Angle 切削角	-5~+15
Grinding Wheel Diameter 砂輪外徑	Ø180 mm
Grinding Wheel Motor 砂輪馬達	0.75 KW
Transmission Motor 傳動馬達	0.37 KW
Grinding Wheel Speed (50Hz / 60Hz) 砂輪轉速	3800/4500 rpm
Net Weight / Gross Weight 淨重/毛重	240 / 335 KG
Package Size 裝箱尺寸	85x113x165 cm

Standard Accessory 標準配備

Work Light 工作燈	1 pc 個
Tool Box 工具箱	1 set 套
Instruction Manual 說明書	1 copy 份
Guide Plate 導板	1 pc 片
Grinding Wheel 砂輪	10 pcs 片

※ All designs, spec. and characteristics shown as above is subject to any change without further notice.
因設計或製造上的需要，如有變更恕不另行通知。