

GTS-250 series



GTS-250 series

TOTAL STATION



High-Performance & High-Quality

- Superior Waterproof and Dustproof
- High Accuracy & Long Measuring Range
- Enhanced Absolute Encoder
- Versatile Application Functions
- Dual-Axis Tilt Sensor

GTS-250 Series Total Station

High-Performance & High-Quality



High Accuracy & Long Measuring Range

- High accuracy: $\pm(2\text{mm}+2\text{ppm} \times D)$ m.s.e.
- Long distance: 2,000m with a Single Prism.

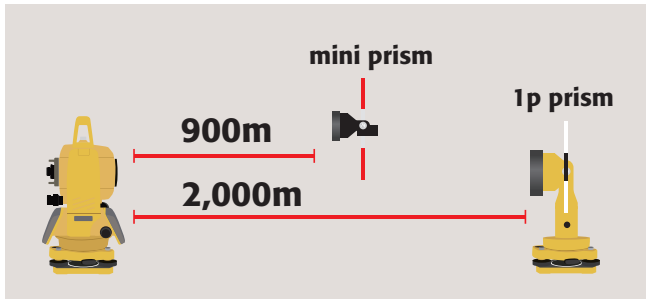

Superior Waterproof and Dustproof

GTS-250 series conform to IEC Standard IP54. No worry about sudden bad weather.

Dual-axis tilt sensor

The dual-axis tilt sensor monitors inclination of both the X and Y axes, and the correct horizontal and vertical angle readings automatically.

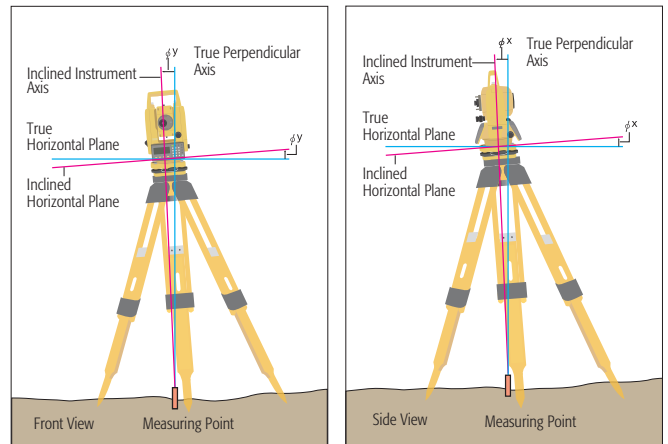

Enhanced Absolute Encoder

GTS-250 Series adopted an absolute encoder system, which doesn't require 0 set and realizes stable measurement with less reading error.

Extra-large memory capacity for 24,000 points

GTS-250 Series store the measured data up to 24,000 points.

Versatile Application Functions

Remote Elevation Measurement (R.E.M.)

To easily determine the height of a point where a prism cannot be placed. Take a distance to a prism placed either directly above or directly below the target point, then sight to the target point.

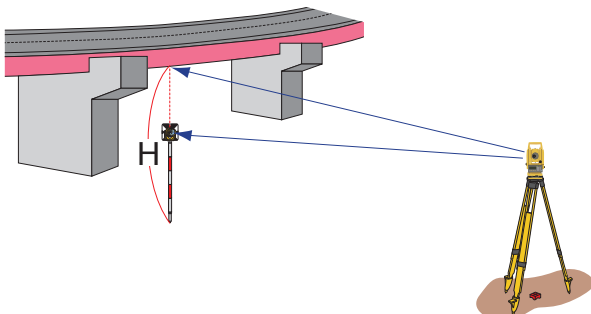

On-board data collection, Survey, Layout, Road Calculation, and many more functions.

Missing Line Measurement (M.L.M.)

To measure horizontal distance, slope distance and height difference between two prisms.

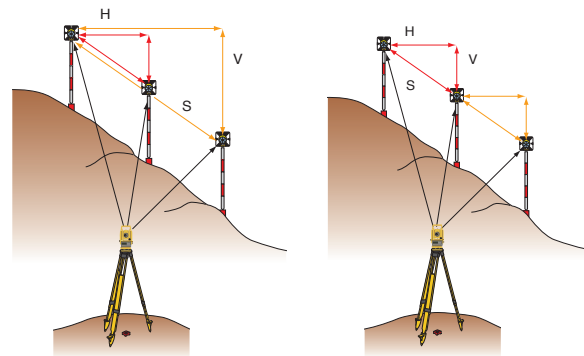

PRIMARY FEATURES

Detachable handle ergonomically designed for easy gripping

Clear and bright telescope
Magnification: 30x
Minimum focus: 1.3m

Instrument center mark

Rough but quick capture of prism by sighting collimator



Rechargeable battery BT-G1W

Optical plummet
Magnification: 3x

Lock and fine adjustment tangent screw.

Telescope grip that enables subtle adjustment

Circular level for easy check

Integrated tribrach with quick lock/release feature

Data exchange with PC via RS-232C port



Easy viewing displays with 4-line, 20-character, with backlight and heater on both faces

Easy-to-use 10-key pads with alphabet entry on both faces

Precise leveling by a highly sensitive plate level

LAYOUT

Layout function for coordinate measurement and control stakeout and resection measurements.

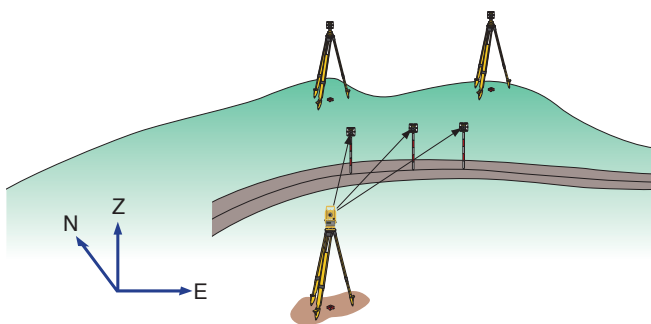

Road

Road function automatically calculates parameters of a complicated spiral curve and a long distance route simply by defining the start point, end point and curve elements.

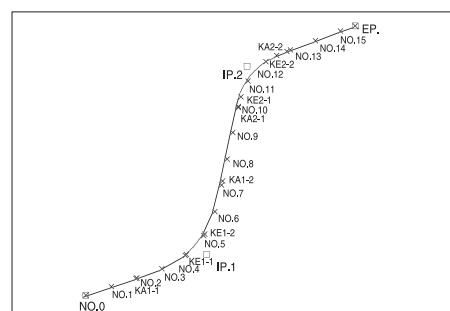

SPECIFICATIONS

Model	GTS-252		GTS-255
Telescope			
Magnification	30x		
Resolving power	3.0"		
Length: 150mm, Objective aperture: 45mm (50mm for EDM), Image: Erect, Field of view: 1°30' (26m/1,000m), Minimum focus: 1.3m			
Angle measurement			
Display resolutions (selectable)	1" / 5" (0.0002 / 0.001 gon)		
Accuracy (ISO 17123-3:2001)	2"	5"	
Method	Absolute rotary encoder scanning		
Detecting system	Horizontal	2 sides	
	Vertical	1 side	
Compensator	Dual-axis liquid tilt sensor, working range: ±3', Correction unit: 1"		
Distance measurement			
Measuring range (under average conditions ^{*1})	Mini prism	900m (3,000ft)	
	One prism	2,000m (6,600ft.) / Under good conditions ^{*2} : 2,300m (7,500ft.)	
	Three prisms	2,700m (8,900ft.) / Under good conditions ^{*2} : 3,100m (10,200ft.)	
Accuracy (D=measuring distance in mm)	±(2mm + 2ppm x D) m.s.e.		
Least count in measurement	Fine: 1mm (0.005ft.) / 0.2mm (0.001ft.), Coarse: 10mm (0.02ft.) / 1mm (0.005ft.), Tracking: 10mm (0.02ft.)		
Measurement time ^{*3}	Fine: 1mm: 1.2s (Initial 4s) / 0.2mm: 2.8s (Initial 5s), Coarse: 0.7s (Initial 3s), Tracking: 0.4s (Initial 3s)		
Interface and Data management			
Display	Graphics LCD, 160 × 64dots		
Keyboard	Alphanumeric 24keys		
Control panel location	On both faces		
Data storage	Internal memory	24,000pts.	
Interface	RS-232C		
General			
Levels	Circular level	10' / 2mm	
	Plate level	30" / 2mm	
Optical plummet telescope	Magnification: 3x, Focusing range: 0.5m to infinity, Image: Erect		
Dust and water protection (With BT-G1W)	IP54 (IEC 60529)		
Operating temperature	-20 to +50°C (-4 to 122°F)		
Size / Instrument height	W184 x D172 x H336mm (W7.2 x D6.8 x H13.2in.) / 176mm (6.93in.) from the tribrach dish		
Weight	Instrument with battery	4.9kg (10.8lbs)	
	Plastic carrying case	3.4kg (7.5lbs), Weight of the carrying case may be slightly different due to specific market.	
Power supply			
Battery (BT-G1W)	Operating time (Fine mode)	Approx. 27 hours (Single distance measurement every 30 seconds at +20°C / +68°F ^{*4})	
		Approx. 9 hours (Continuous distance measurement at +20°C / +68°F)	
Battery charger	Recharging time	1.8 hours (+10 to +40°C)	

^{*1} Average conditions: Slight haze with visibility about 20km (12.5 miles) moderate sunlight with light heat shimmer. ^{*2} Good conditions: No haze with visibility about 40km (25 miles), overcast with no heat shimmer.
^{*3} The initial time will be different by a condition and setting EDM off time. ^{*4} On the condition EDM off time is set at 0 minutes.



Standard Accessories

- Main unit x 1
- Battery (BT-G1W) x 1
- Battery Charger x 1
- Lens cap x 1
- Tool kit with case x 1
- Plastic rain cover x 1
- Silicon cloth x 1
- Carrying Case x 1

- Specifications subject to change without notice.
 - Other trademarks and trade names are those of their respective owners.



TOPCON CORPORATION

75-1 Hasunuma-cho, Itabashi-ku, Tokyo 174-8580, Japan
 Phone: (+81)3-3558-2993 Fax: (+81)3-3960-4214
www.topcon.co.jp

Your local Authorized Topcon dealer is: